

Hope530 High performance LV Drive

Naming Rules for Products

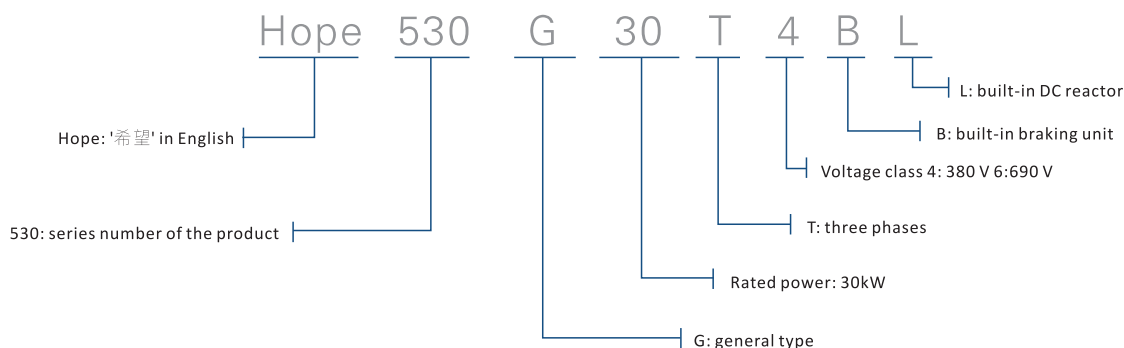

Features

- Control mode: VF, VF+PG, SVC, closed-loop Vector Control
- Strong overload capacity: 150% 60s, 180% 15s, 200% 2s
- 2 groups PID parameters
- Optional IO/ Encoder/ Communication card
- Integrated logic control: Comparator, logic, timer, arithmetic unit

Specifications

Power Range	380V: 0.75~375kW 660V: 18.5~375kW
Power input	3ph: 380V/660V (-15%~+10%), 47~63Hz
Power output	Voltage: 0~Vin Frequency: 0~400Hz
Overload Capacity	150% of rated current: 60s 180% of rated current: 15s 200% of rated current: 2s
I/O resource	5DI, 2DO, 2RO, 2AI, 2AO, 1PFI, 1PFO
Control Mode	VF, SVC, FVC
DBU/	DBU: ≤22kW built-in, 30-160kW optional internal
DC reactor	90-375kW built-in DC Reactor, others optional
Features	Integrated internal logic control function, Built-in Modbus, optional IO/ Encoder/ Communication card (Profibus, Profinet, EtherCAT) / LCD display

■ Rated specifications

380V:

Inverter model	Rated capacity (kVA)	Rated output current (A)	Adaptive motor(kW)	Inverter model	Rated capacity (kVA)	Rated output current (A)	Adaptive motor(kW)
Hope530G0.75T4B*	1.6	2.5	0.75	Hope530G55T4**	74	112	55
Hope530G1.5T4B*	2.4	3.7	1.5	Hope530G75T4**	99	150	75
Hope530G2.2T4B*	3.6	5.5	2.2	Hope530G90T4*L	116	176	90
Hope530G4T4B*	6.4	9.7	4	Hope530G110T4L	138	210	110
Hope530G5.5T4B*	8.5	13	5.5	Hope530G132T4L	167	253	132
Hope530G7.5T4B*	12	18	7.5	Hope530G160T4L	200	304	160
Hope530G11T4B*	16	24	11	Hope530G200T4L	248	377	200
Hope530G15T4B*	20	30	15	Hope530G220T4L	273	415	220
Hope530G18.5T4B*	25	38	18.5	Hope530G250T4L	310	475	250
Hope530G22T4B*	30	45	22	Hope530G280T4L	342	520	280
Hope530G30T4**	40	60	30	Hope530G315T4L	389	590	315
Hope530G37T4**	49	75	37	Hope530G375T4L	460	705	375
Hope530G45T4**	60	91	45	-	-	-	-

660V:

Inverter model	Rated capacity (kVA)	Rated output current (A)	Adaptive motor(kW)	Inverter model	Rated capacity (kVA)	Rated output current (A)	Adaptive motor(kW)
Hope530G18.5T6 *L	25	22	18.5	Hope530G132T6L	176	148	132
Hope530G22T6* L	29	25	22	Hope530G160T6L	195	171	160
Hope530G30T6* L	38	33	30	Hope530G200T6L	240	210	200
Hope530G37T6* L	51	45	37	Hope530G220T6L	274	240	220
Hope530G45T6*L	62	54	45	Hope530G250T6L	328	287	250
Hope530G55T6*L	74	65	55	Hope530G280T6L	360	315	280
Hope530G75T6*L	103	86	75	Hope530G315T6L	406	355	315
Hope530G90T6L	116	102	90	Hope530G375T6L	440	385	375
Hope530G110T6L	138	122	110	—	—	—	—

■ Installation

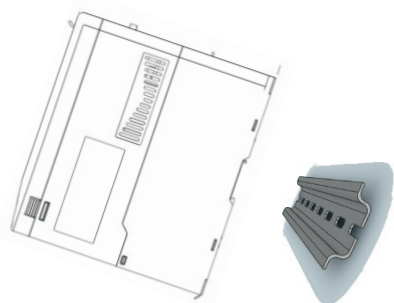

DIN Rail

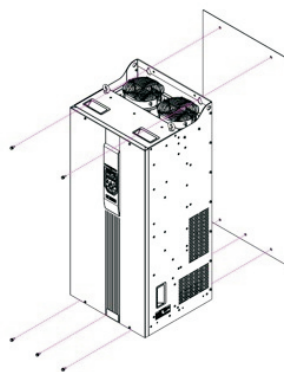

Wall mounted

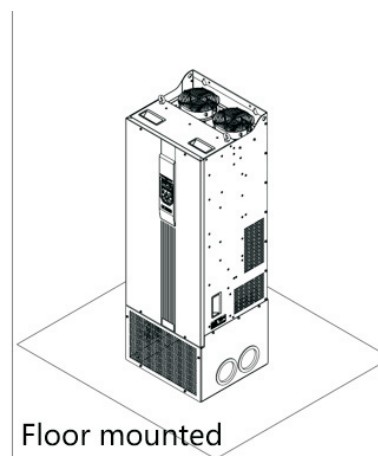

Floor mounted

Hope530 High performance LV Drive

■ Dimension

Inverter model	W(mm)	W1(mm)	H(mm)	H1(mm)	D(mm)	d(mm)	Weight without reactor (kg)	Weight with reactor (kg)
Hope530G0.75T4B*	100	90	200	190	180	5	2.5	2.2
Hope530G1.5T4B*	100	90	200	190	180	5	2.5	2.2
Hope530G2.2T4B*	100	90	200	190	180	5	2.5	2.2
Hope530G4T4B*	100	90	200	190	180	5	2.5	2.2
Hope530G5.5T4B*	130	120	260	250	180	5	3.8	3.5
Hope530G7.5T4B*	130	120	260	250	180	5	3.8	3.5

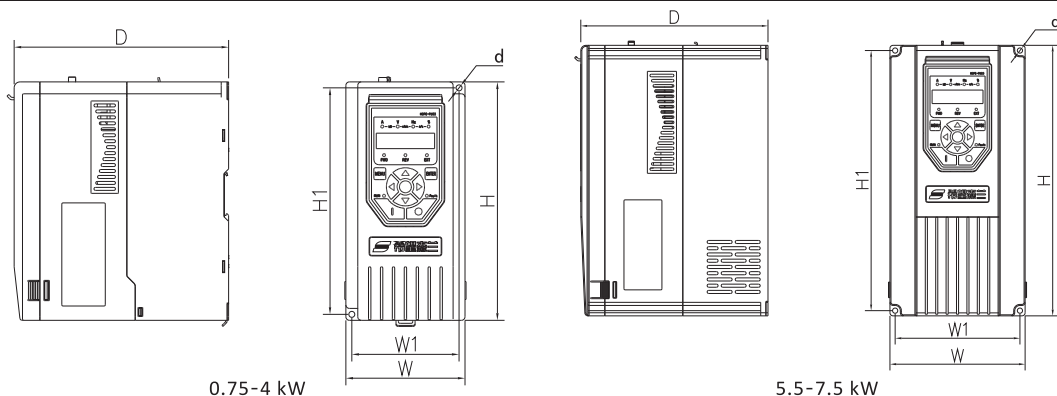

Inverter model	W(mm)	W1(mm)	W2(mm)	H(mm)	H1(mm)	H2(mm)	H3(mm)	D(mm)	d(mm)	Weight without reactor (kg)	Weight with reactor (kg)
Hope530G11T4B*	170	160	190	300	290	5	310	192	5	6	5.5
Hope530G15T4B*	170	160	190	300	290	5	310	192	5	6.8	6.2
Hope530G18.5T4B*	208	195	230	352	337	5	360	203	6	10	7
Hope530G22T4B*	208	195	230	352	337	5	360	203	6	11	7.5
Hope530G30T4**	248	230	270	400	382	10	410	234	7	18.5	12.6
Hope530G37T4**	248	230	270	400	382	10	410	234	7	19.5	12.7

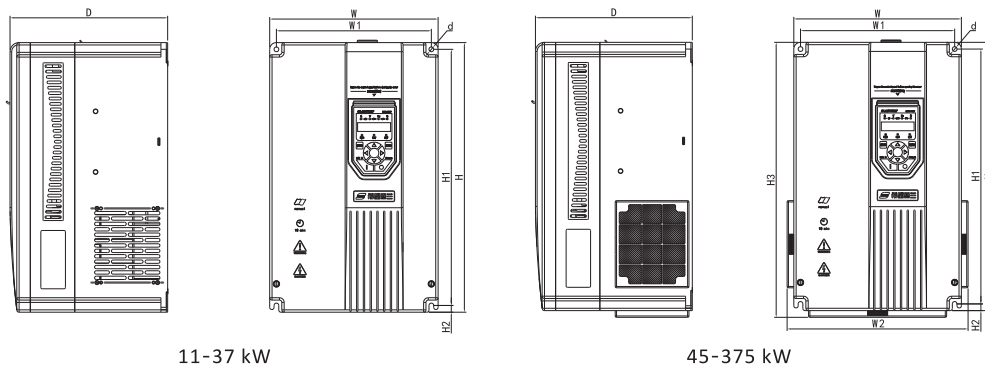

Inverter model	W(mm)	W1(mm)	H(mm)	H1(mm)	H2(mm)	H3(mm)	D(mm)	d(mm)	R(mm)	Weight without reactor(kg)	Weight with reactor(kg)
Hope530G45T4**	300	245	545	525	10	620	300	10	5	32.5	28.1
Hope530G55T4**	300	245	545	525	10	620	300	10	5	33.3	28.1
Hope530G75T4**	340	270	580	562	10	676	326	10	5	51.2	38
Hope530G90T4*L	340	270	580	562	10	676	326	10	5	51.2	—
Hope530G110T4*L	340	270	580	562	10	676	326	10	5	51.5	—
Hope530G132T4*L	400	320	915	895	10	1013	355	10	5	96.5	—
Hope530G160T4*L	400	320	915	895	10	1013	355	10	5	97.5	—
Hope530G200T4L	440	300	1000	975	10	1170	395	11	5.5	140	—
Hope530G220T4L	440	300	1000	975	10	1170	395	11	5.5	140	—
Hope530G250T4L	485	300	1130	1100	12	1300	400	12	6	200	—
Hope530G280T4L	485	300	1130	1100	12	1300	400	12	6	200	—
Hope530G315T4L	650	490	1150	1125	10	1320	400	11	5.5	240	—
Hope530G375T4L	650	490	1150	1125	10	1320	400	11	5.5	240	—

Wiring diagram

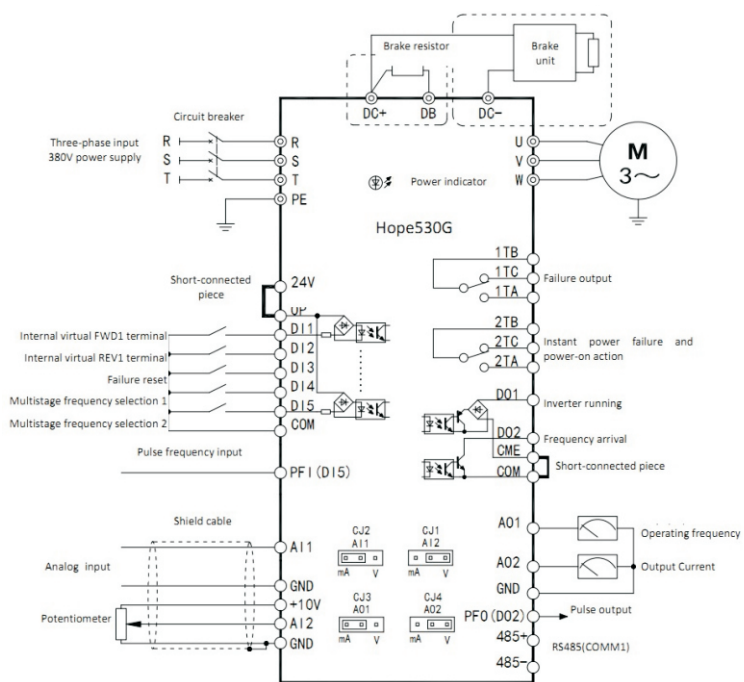

Extension Card

